

SP4ST OSCILLATOR



Specifications		
Parameters	Standard	Options
Frequency range	10,000 MHz - 60,0 MHz	
Logic output	Clipped sinewave	Sinewave
Frequency stability		
Overall	+/- 5,0 ppm	+/-1,5 ppm best possible
Initial at 25°C	Please specify	
Temperature		
vs supply voltage change		
vs load change		
Aging first year		
Aging over Years		
Operating temperature	0° C ~ +70°C	-20°C ~ +70°C
		-40°C ~ +85°C
		Other on custom request
Storage temperature	-40°C ~ +85°C	-55°C ~ +125°C
Supply voltage	3,3 V +/-5%	5,0 V ± 5%
		Other on custom request
Current	2,0 mA max	
Load	10 Kohm // 10 pF	Other on custom request
Jitter (12kHz ~ 20,0 MHz)	3-4 ps typ.	Other on custom request
Phase noise	Please specify (if required)	
Harmonics		
Sub-harmonics		
Start-up time	10 ms max.	Other on custom request
Frequency trimming range with externally adjustable trimmer	± 3 ppm min.	other
Marking	Freq + Code + Week +Year	

SP4ST OSCILLATOR

Specifications

Voltage Control Options

External control voltage	+ 1,65 VDC \pm 1,65 VDC (3,3V) +2,5 VDC \pm 2,5 VDC (5,0V)	Other on custom request
Linearity	\pm 10% max.	Other on custom request
Frequency tuning range	\pm 10 ppm	Other on custom request
Pulling slope	Positive	Other on custom request

Drawing

Options

Package	SP4 4 pad	SP4 6 pad
---------	-----------	-----------

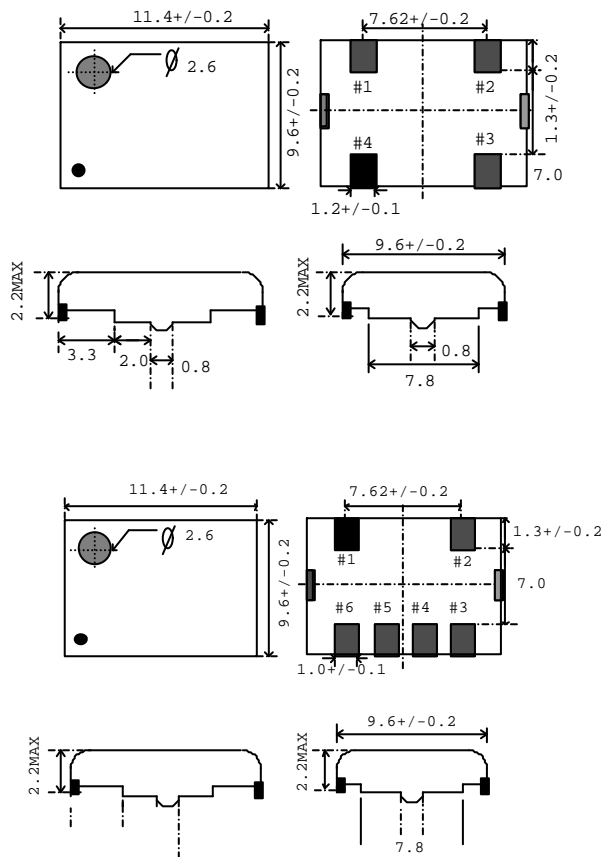

Pin configuration	#1 : NC / Vco	#1 : NC / Vco
	#2 : GND	#2 : GND
	#3 : Output	#3 : Output
	#4 : Vcc	#4 : GND
		#5 : NC
		#6 : Vcc

HM International
 Demer 26 B-2230 Herselt BELGIUM
 Tel. +32(0)14548955 Fax. +32(0)14549443
 email : info@hminternational.be www.hminternational.be